

For best effects, use tissue foil of at least 20 cm square. Fold and unfold, creasing well.

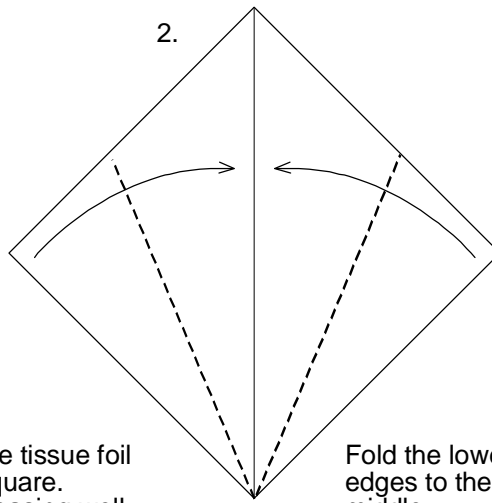

Fold the lower right and left edges to the crease line in the middle.

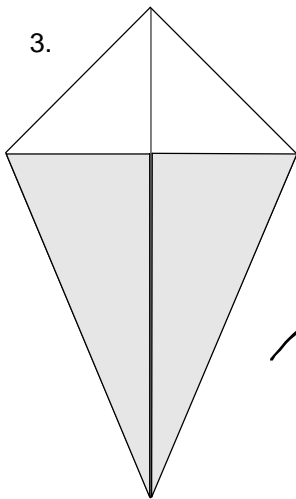

Turn paper over.

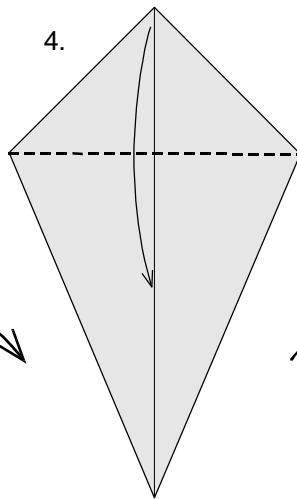

Fold down and turn over again.

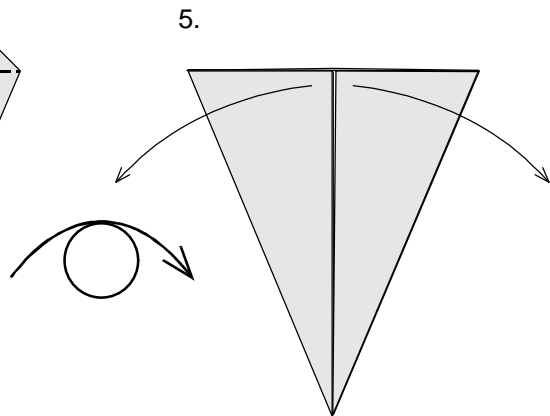

Unfold Step 2 ...

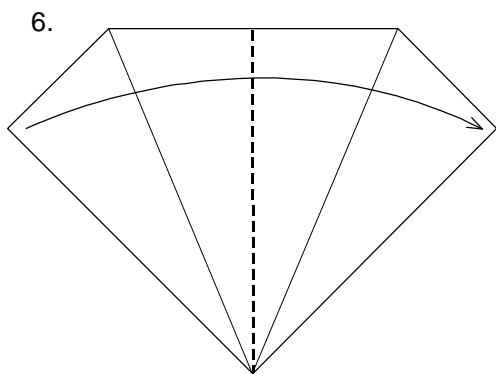

... then fold in half.

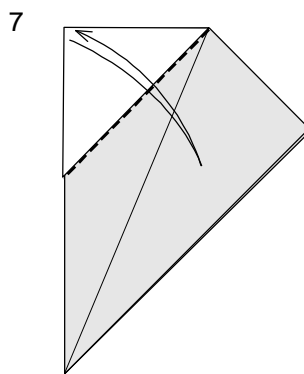

Fold and unfold, creasing firmly.

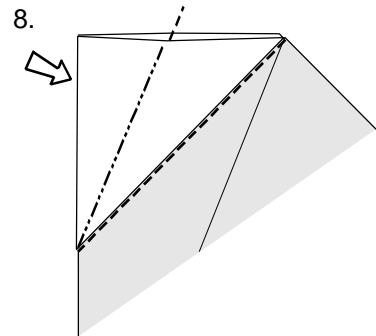

Squash fold ...

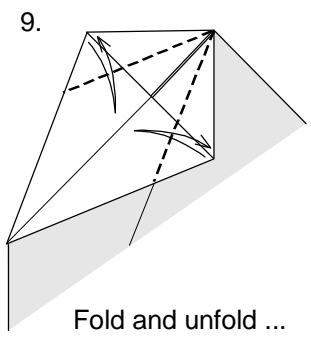

Fold and unfold ...

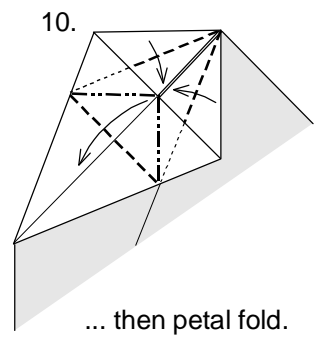

... then petal fold.

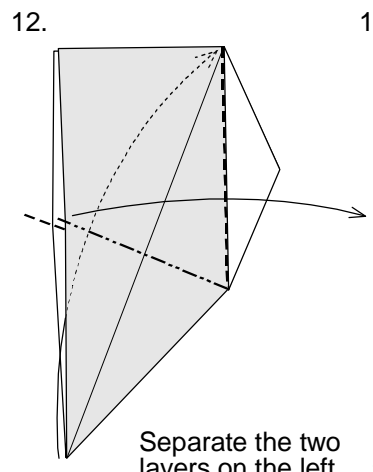
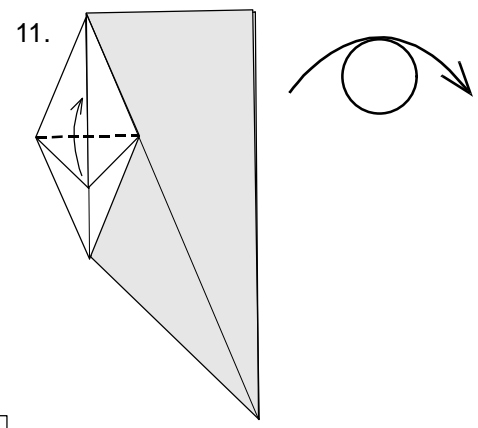

Separate the two layers on the left and squash fold.

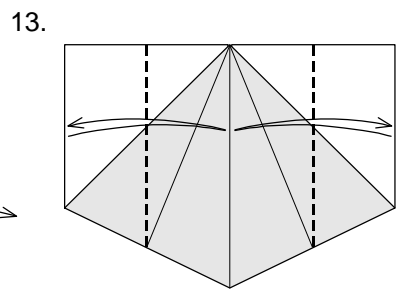

Fold and unfold again on the left and right, dividing the horizontal length into quarters.

Fold up the little triangle in the centre and turn paper over.

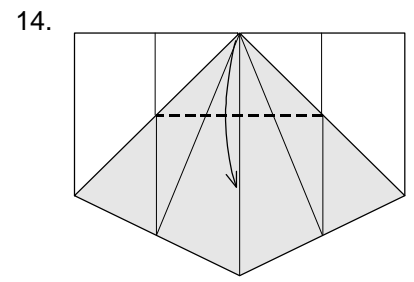

Fold down the triangle portion at the top where the creases made in Step 13 intersect the edges of the top layer.

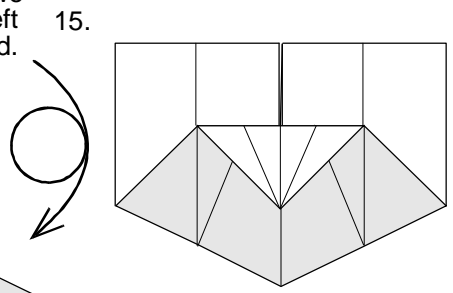

flip paper over vertically.

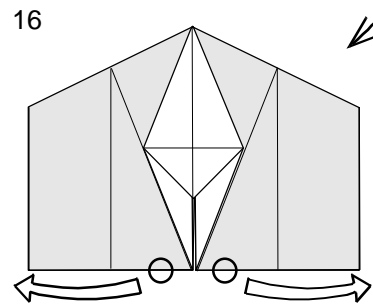

Grasp the paper firmly at the circled position and pull apart.

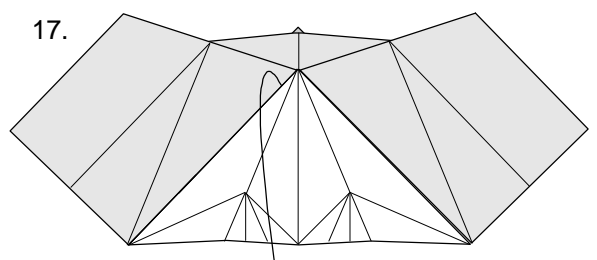

Open out the overlapping triangle ...

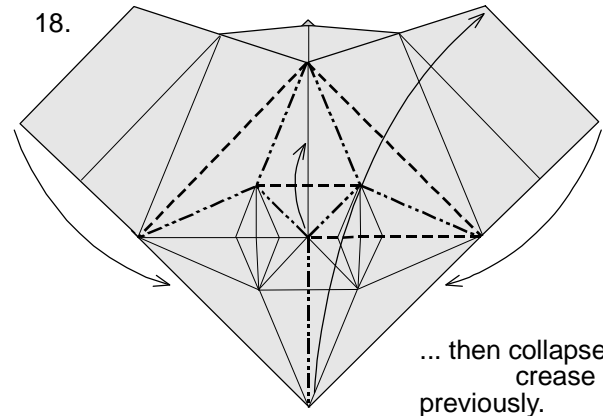

... then collapse as shown along crease lines made previously.

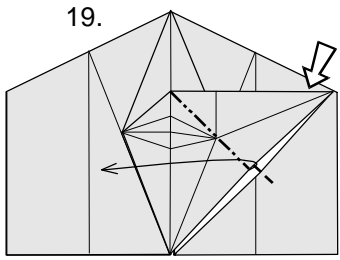

19. Separate the two layers and squash fold.

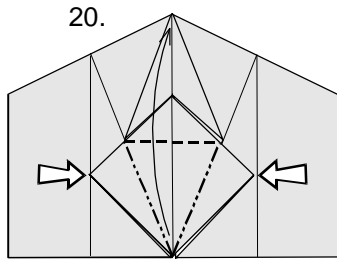

20. Reverse fold each of the two sides as you bring up the flap in the centre.

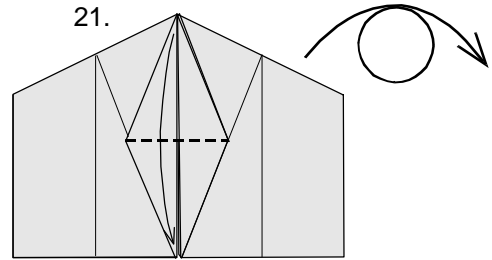

21. Now bring down the central flap and turn paper over.

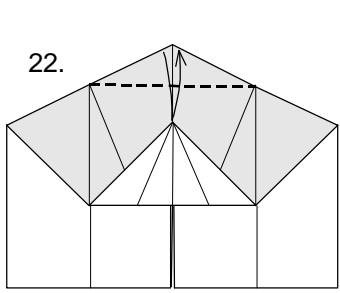

22. Fold and unfold as shown, creasing firmly.

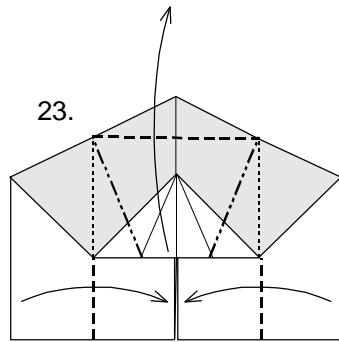

23. Bring up the top layer along creases made previously as you fold in the sides ...

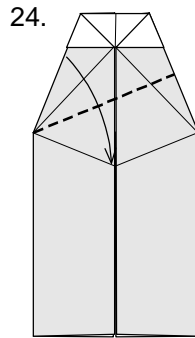

24. ... like so. Fold down, aligning with the edge of the underlying layer ...

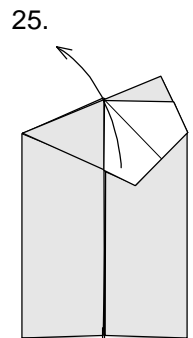

25. ... and unfold.

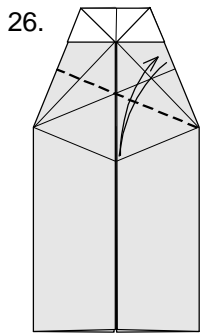

26. Repeat Steps 24 and 25 on the right ...

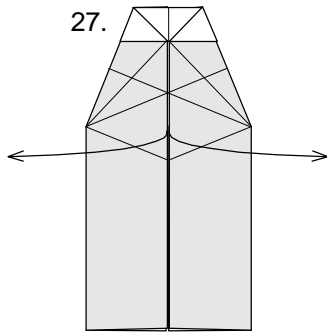

27. ... then open out as illustrated ...

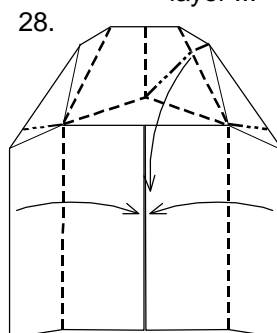

28. ... and collapse along creases made

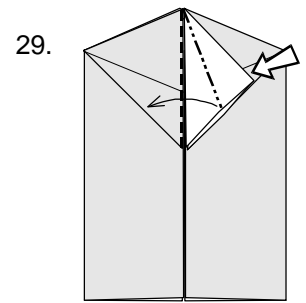

29. ... like this. Now squash fold.

previously ...

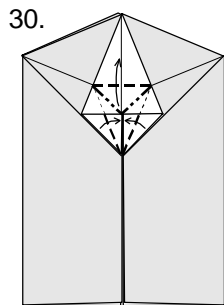

30. Petal fold, then fold through Steps 11 and 16 to 20 for this part of the assembly.

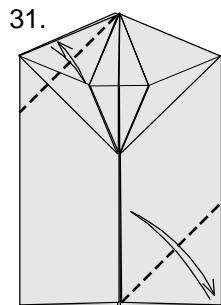

31. Fold and unfold at the top and bottom, creasing firmly ...

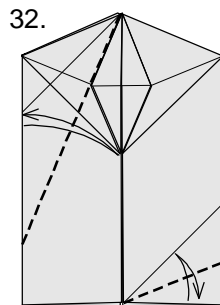

32. ... again ...

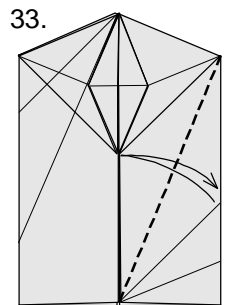

33. ... and again.

34.

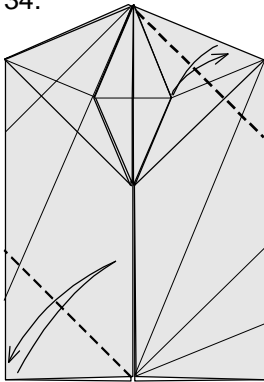

Repeat Steps 31 to 33 on the opposite sides.

35.

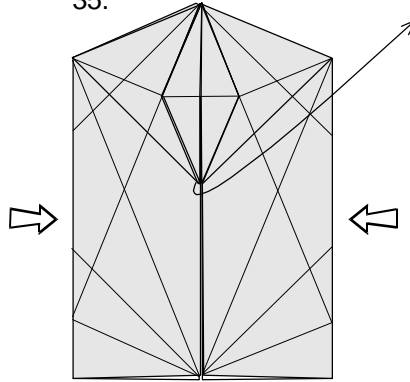

Separate the two layers at the top and bottom and open out by letting the two pieces in front, flattening the sides together.

36.

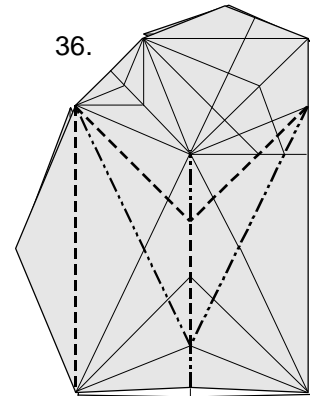

Collapse the top layer only, along crease lines made previously, like this ...

37.

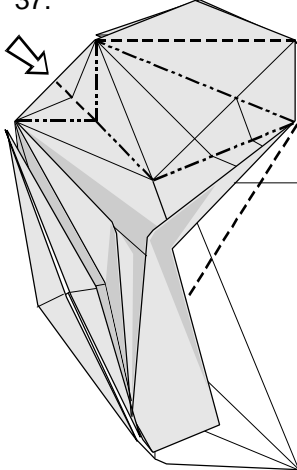

... and like this, repeating behind.

38.

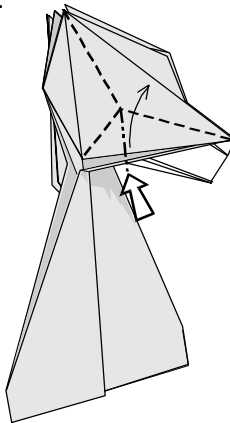

Rabbit's ear as shown, repeating behind to flatten out ...

39.

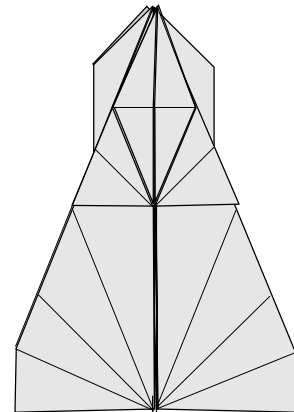

... like so.

40.

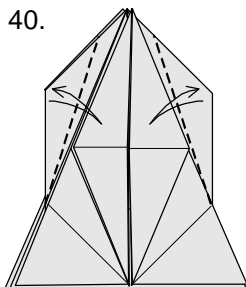

This is a close up of the upper section. Fold and unfold each of the two sides as shown, creasing firmly.

41.

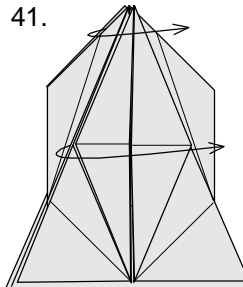

Separate the two layers at the top and side and open to the right ...

42.

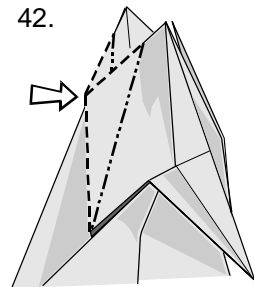

... then sink along crease lines made in Step 40 ...

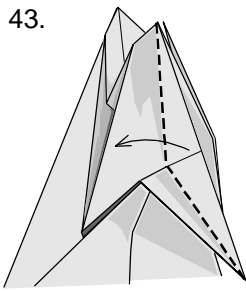

... and then close to the left.

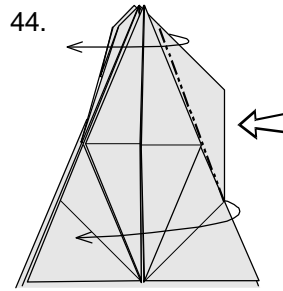

Repeat Steps 41 to 43 on the right.

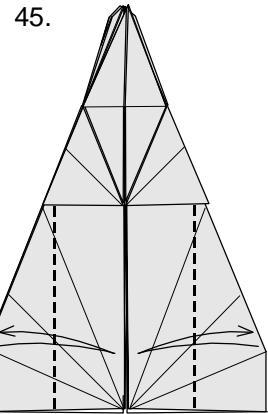

Fold and unfold, creasing well.

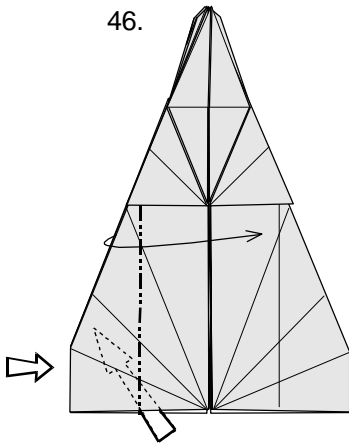

Separate the two layers on the side and push from below to flatten out ...

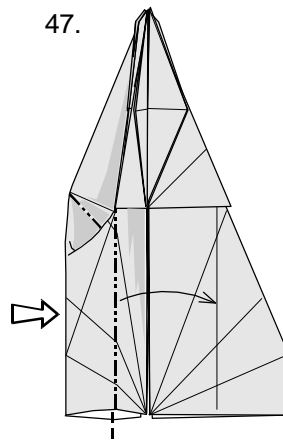

... ever so carefully ...

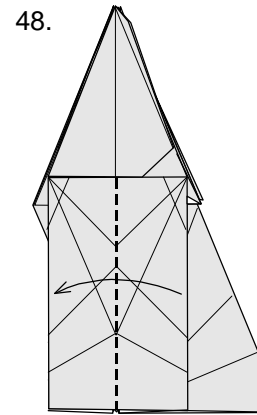

... like so. Now valley fold and close to the left.

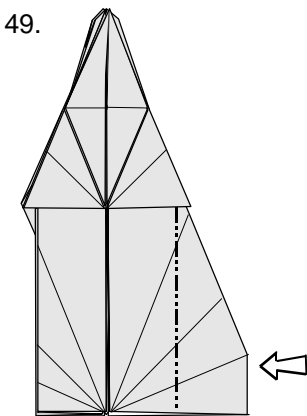

Repeat Steps 46 to 49 on the right. Fold up the flaps in the middle, bringing the corners at the bases together as in diagram 51.

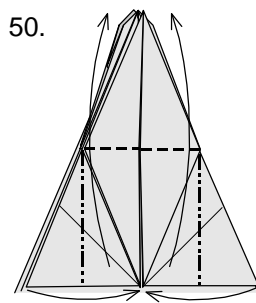

This is a close up of the top portion of the model. Fold up the frontal pieces as shown, bringing the corners at the bases together ...

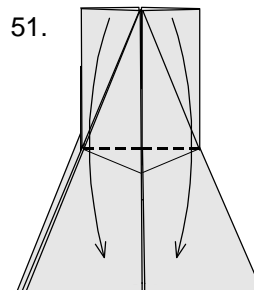

... like this, then fold down again, keeping the corners together.

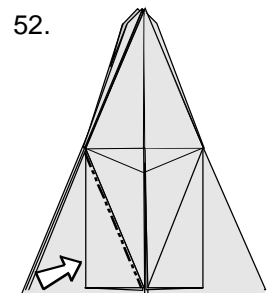

Reverse fold on the left.

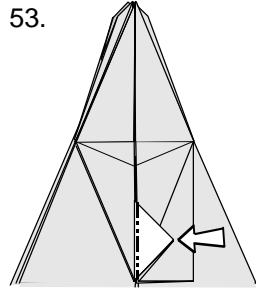

Reverse fold again ...

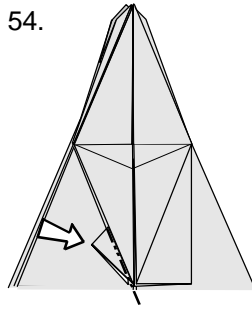

... and again.

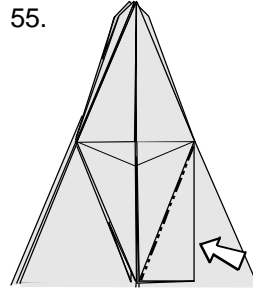

Repeat Steps 52 to 54 on the right to complete the top for now.

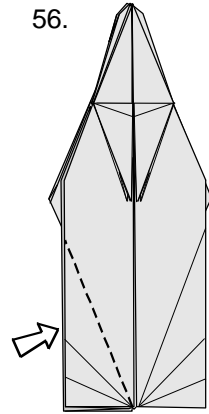

Reverse fold the top layer on the left.

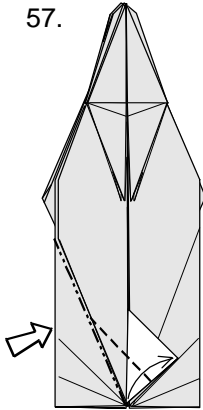

Valley fold the upper layer as shown, then reverse fold the second layer on the left.

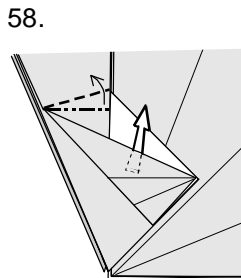

Crimp fold the top layer while opening out the hidden pleats ...

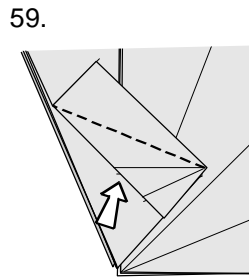

... like this. Reverse fold.

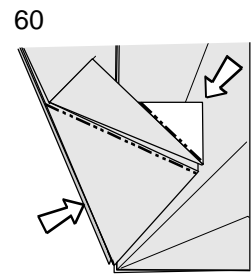

Reverse fold the next layer on the left, and reverse fold on the right again

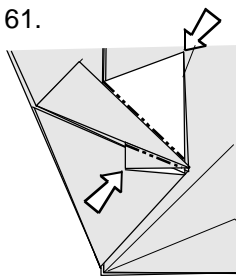

Two more reverse folds ...

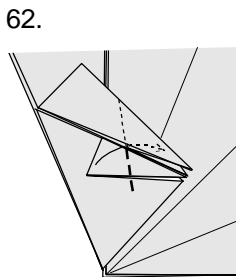

... then valley fold ...

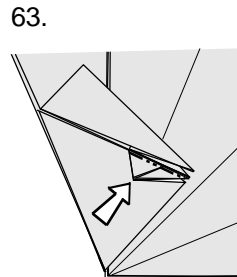

... before finishing off with yet another reverse fold.

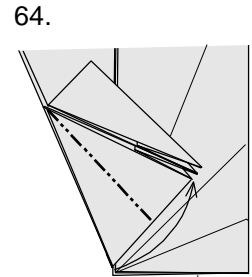

Repeat Steps 57 to 61 for the remain layer on the left.

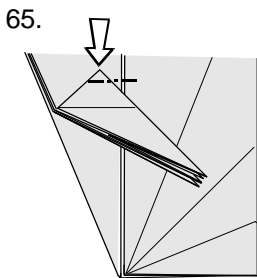

Sink fold and repeat behind, then repeat from Step 56 on the right half of the model.

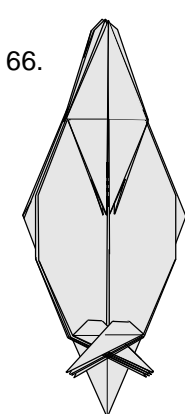

The model should now look like this.

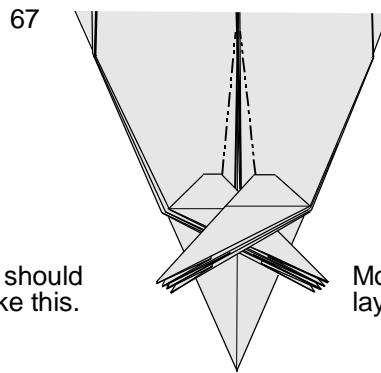

Mountain fold, the top layer only, as shown.

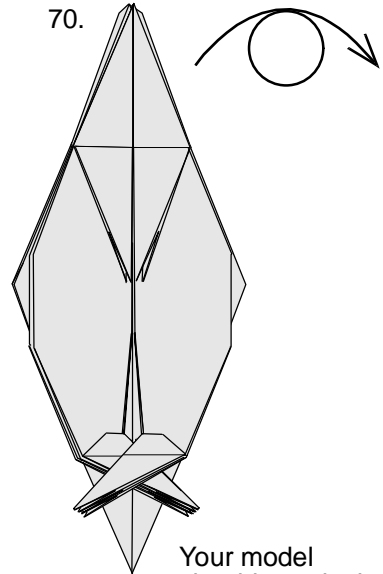
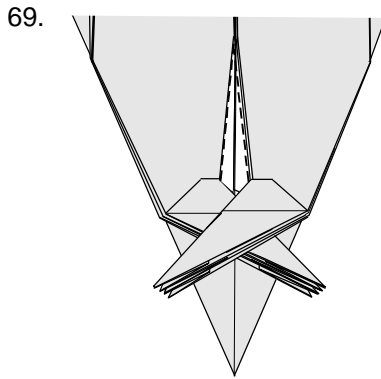
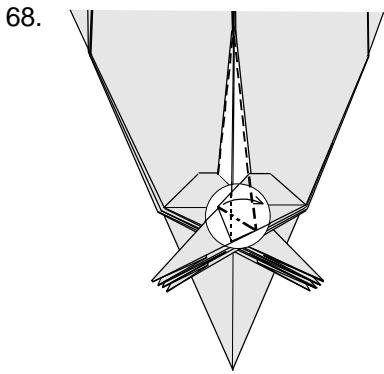

Valley fold the next layer under, forming a gusset with the hidden layers at the bottom...

.. then valley fold the third and fourth layers together.

Your model should now look like this. Turn model over.

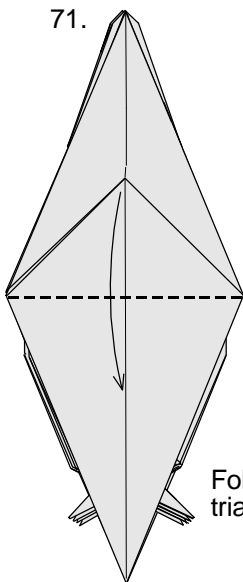

Fold down this triangle piece ...

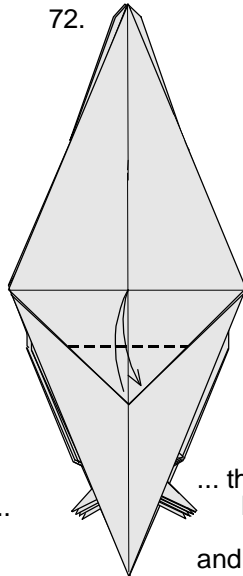

... then fold half its height upwards, crease well, and unfold.

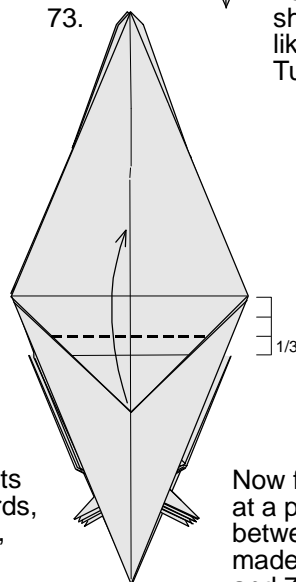

Now fold up again, at a point one-third between the lines made in Steps 71 and 72 as shown.

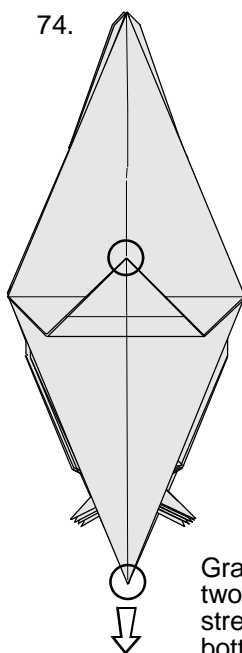

Grasp the model at the two circled locations and stretch by pulling the bottom point downwards.

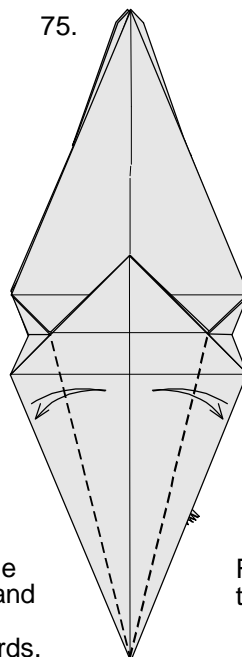

Fold and unfold each of the two sides, creasing firmly.

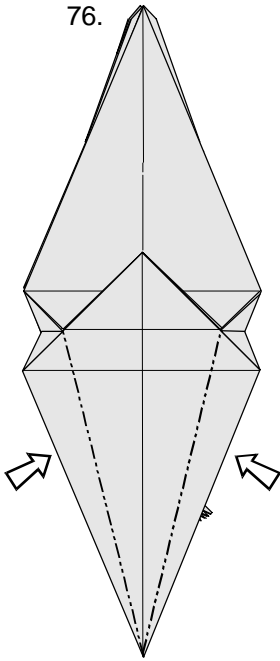

76. Sink along crease lines made in Step 75, as in Step 42.

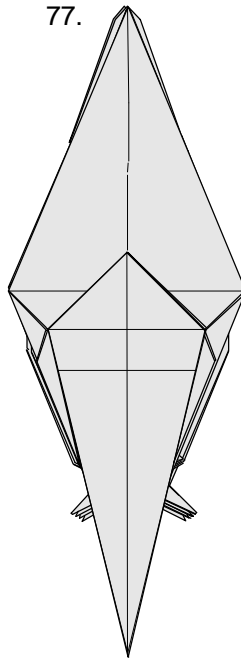

77. Turn model over.

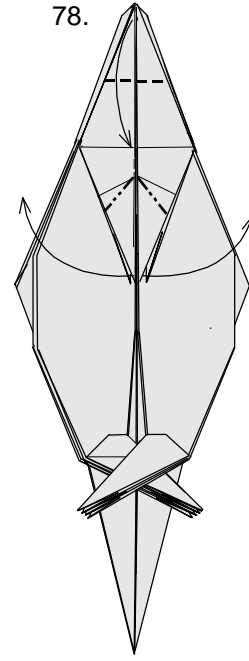
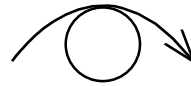

78. Reverse fold the points in the middle at differing angles, separating the two upper layers from the four layers below. Fold down the uppermost layer at the top as illustrated.

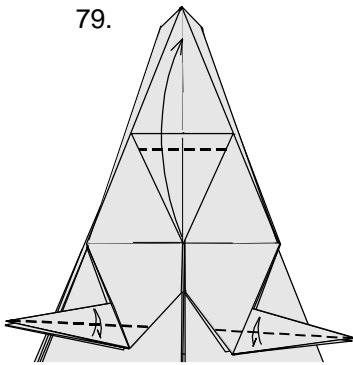

79. Fold up at the top again, then fold and unfold the lower points as illustrated.

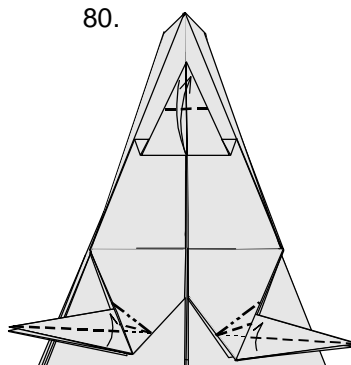

80. Fold down at the top. Next, narrow the points at the bottom while tucking the overlapping layers under as shown.

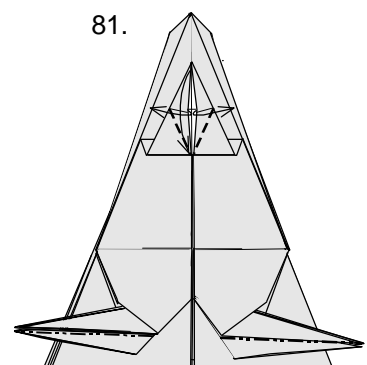

81. Open out to separate the left and right sides while bringing the tip down again. Narrow the inner halves of the lower points as in Steps 79 and 80.

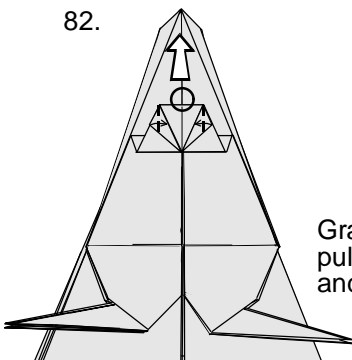

82. Grasp the circled area and pull up to unfold Steps 78 and 79 ...

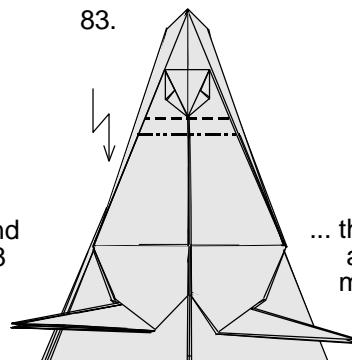

83. ... then crimp fold to reverse along the crease lines made previously ...

84.

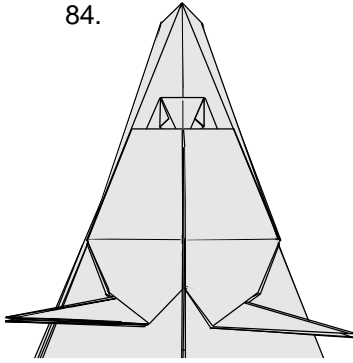

This is how your model should look after Step 83.

85.

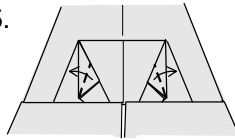

Fold the lower corners over ...

86.

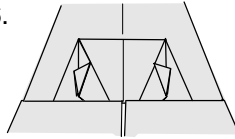

.. like this. These will be the eyes.

87.

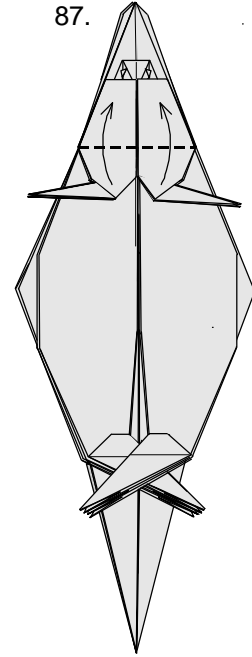

Fold up the central pieces. These will be the forelegs.

88.

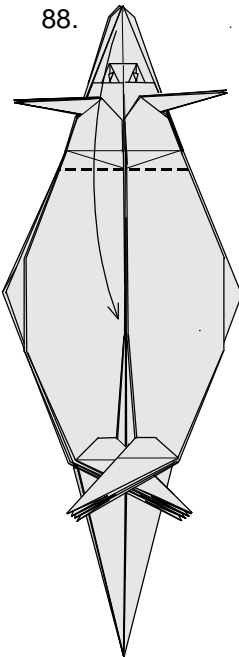

Fold down the top portion at the point shown in the illustration.

89.

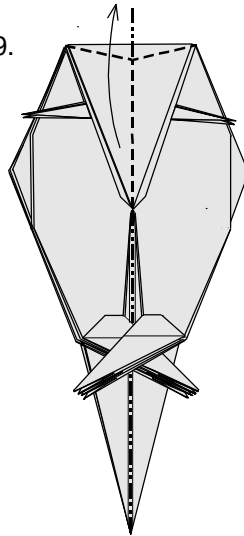

Crimp fold at the top while folding the model in half ...

90.

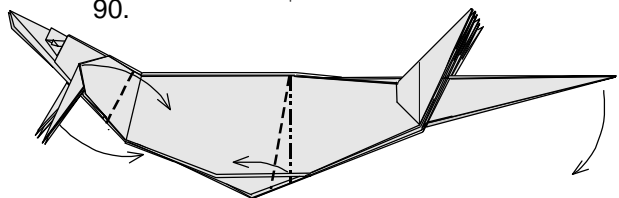

... like this.
Crimp fold both sides of the body.
Fold down the forelegs again.

91.

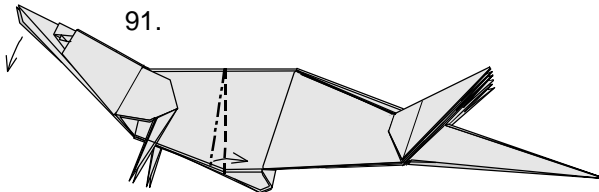

Crimp fold both sides of the body again ...

92.

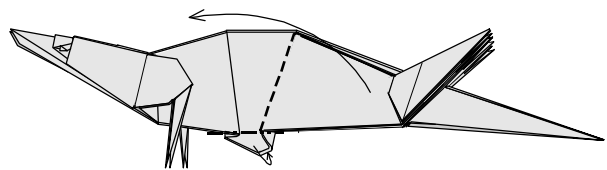

... then bring up the hind leg.
Hide the excess paper at the belly with a mountain fold into the body.

93.

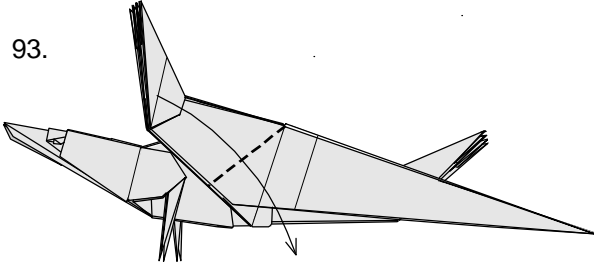

Valley fold down again.

94.

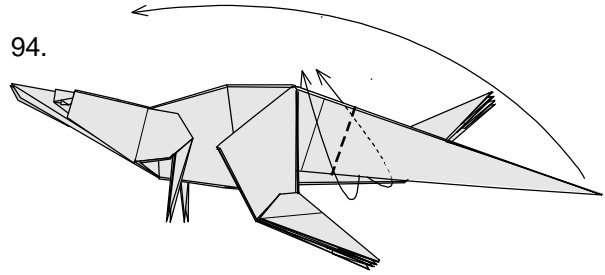

Repeat Steps 92 and 93 on the other hind leg, at a slightly different angle for greater realism. Outside reverse fold the tail as illustrated.

95.

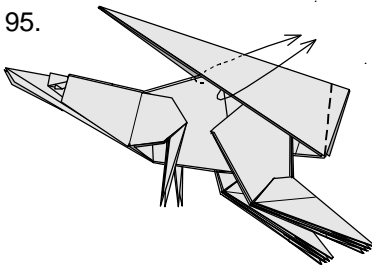

Outside reverse fold again, crimping the tail.

96.

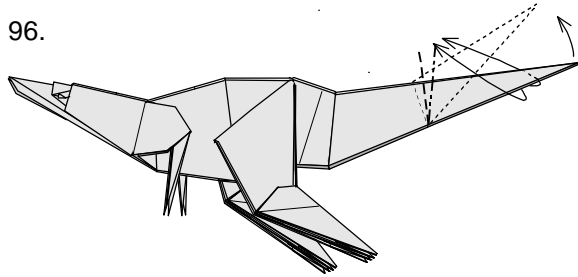

Repeat Steps 94 and 95 along the indicated position on the tail.

97.

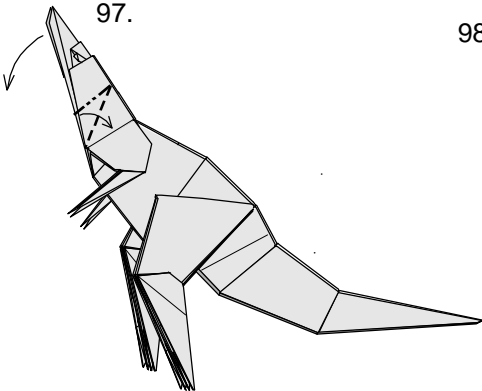

Crimp fold separately on each side of the model as illustrated.

98.

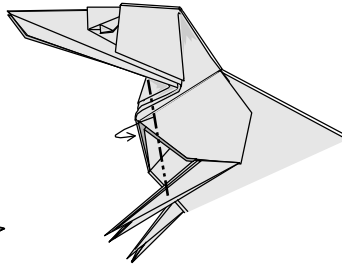

Mountain fold the excess paper into the body. Repeat on the other side.

99.

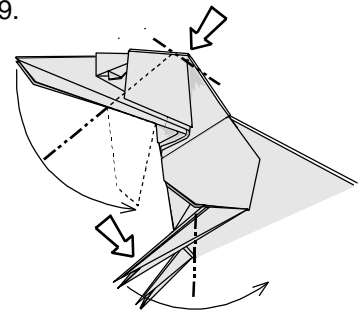

Reverse fold the foreleg and lower half of the mouth piece. Sink fold the corner at the back of the head.

100.

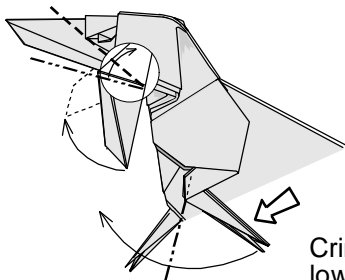

Crimp fold both sides of the lower jaw within the head as illustrated. Reverse fold the foreleg again.

101.

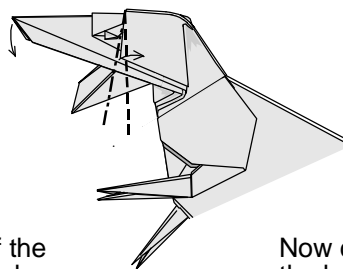

Now crimp fold both sides of the head to bring the upper jaw downwards.

102.

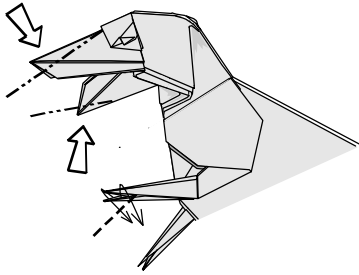

Outside reverse fold the lower point on the foreleg. Reverse fold the upper and lower jaws at the illustrated angles.

103.

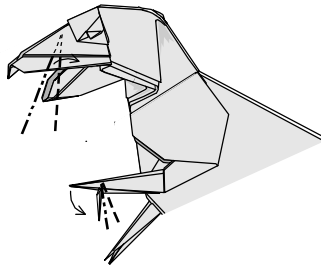

Crimp fold both sides of the upper point on the foreleg. Next, crimp fold both sides of the lowest layer of the upper jaw, drawing out the overlapping layers at the nose as you do so.

104.

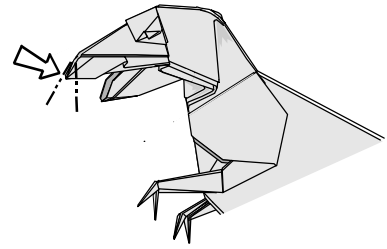

Repeat Steps 102 and 103 on the other foreleg, differing the angles slightly. Reverse fold again at the nose.

104.

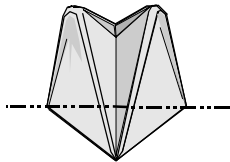

This is a close up of the front of the upper jaw. Mountain fold the triangle under ...

105.

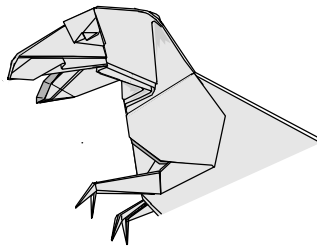

... and the head is finished.

106.

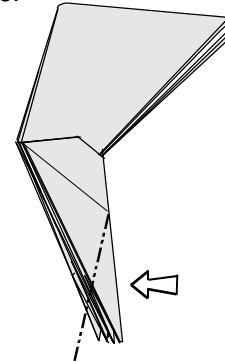

And now for the left hind leg. Reverse fold the uppermost layer as shown, making a gusset at the top.

106.

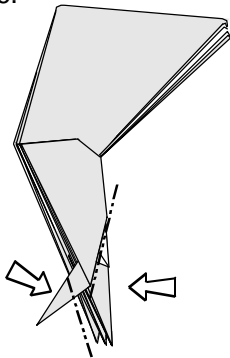

Repeat Step 105 on the next two points on the right, then reverse fold the point on the left again as shown.

107.

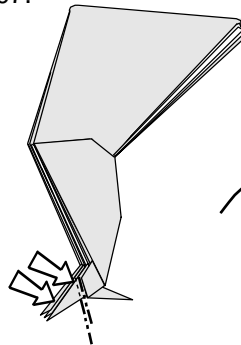

Repeat Step 106 on the first two point on the left. Turn model over.

108.

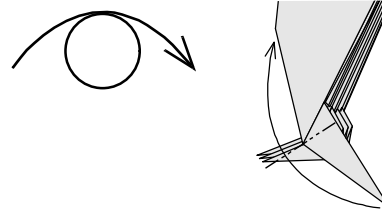

Reverse fold the last point all the way into itself ...

109.

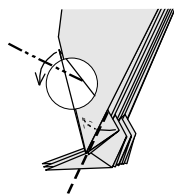

Reverse fold the hidden tip on the left, then tuck in the excess paper on the right ...

110.

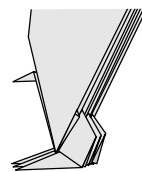

... like this. Turn model over again.

111.

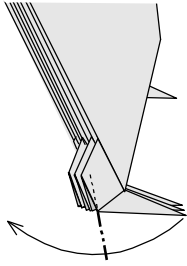

You will need to fold each of the three similar points one at a time from Step 111 through 114. Reverse fold ...

112.

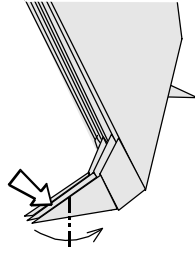

... again ...

113.

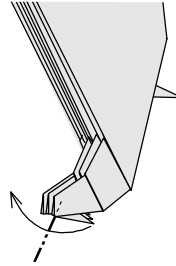

... and again ...

114.

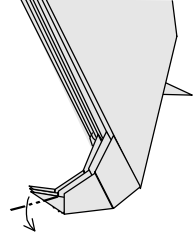

... and yet again.

115.

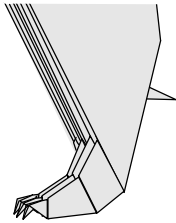

The foot should now look like this. Complete the other foot.

116.

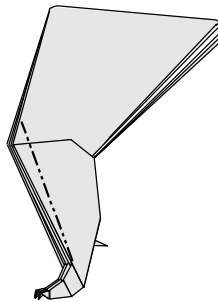

Divide the layers on the left side equally in two, then mountain fold each side to narrow the lower leg.

117.

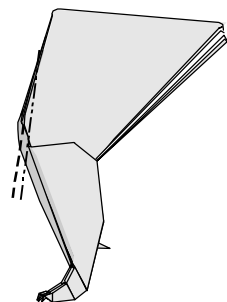

Do the same for the thigh.

118.

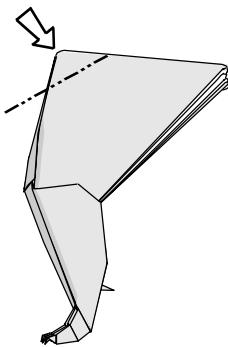

Reverse fold the corner of the upper thigh. Complete the other leg and you're all done!

